

## Installation and Assembly Instructions EGA (Advantage Series Enclosed & Gasketed)

### **WARNING**

#### Risk of fire, electric shock, injury or property damage

Risk of electric shock--Disconnect power to equipment before installing or servicing.  
This equipment must be installed according to all applicable codes & ordinances.  
Installation and service of this equipment must be performed by qualified service personnel.  
Do not install damaged equipment.  
Read these instructions before installing, servicing or maintaining this equipment.  
Save these instructions for maintaining and servicing.

### **CAUTION**

Failure to follow instructions or altering equipment could result in damage and void warranty.  
Edges may cut--wear gloves while handling or servicing this equipment.  
Inspect equipment for damage from shipping and handling.

### LUMINAIRE PREPARATION

1. Remove the luminaire from the carton and inspect luminaire for damage. Do not install a damaged luminaire.

### WIRING INFORMATION

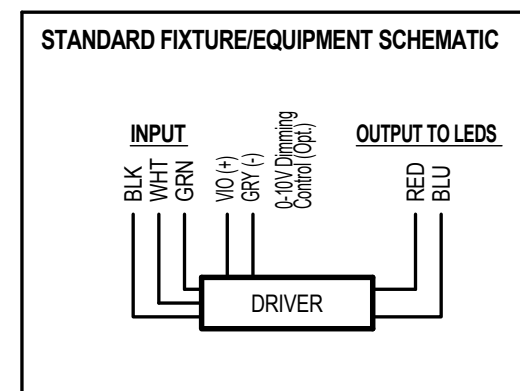
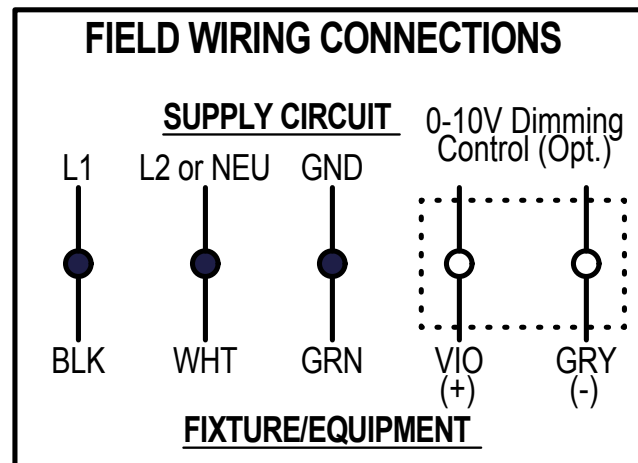

Installation Questions  
Call LSI Field Service Dept.  
800-436-7800 Fax 877-861-1368

## Installation and Assembly Instructions EGA (Advantage Series Enclosed & Gasketed)

### MOUNTING (Chain and Cable)

1. Attach chain or cable to the fixed mounting points.
2. Attach hanger brackets to cable or chain.
3. Hanger brackets are attached to housing by fitting brackets over top portion of fixture.
4. Insure fixture is level.
5. Make wiring connections (see below)

### MOUNTING (Surface)

1. Secure hanger brackets to desired location.
2. Hanger brackets are attached to housing by fitting brackets over top portion of fixture.
3. Make wiring connections (see below).

### WIRING

1. Turn off electrical supply at the breaker.
2. Remove lens by opening hinges on both sides.
3. Remove reflector.
4. Pull building supply leads into the housing.
5. Follow all local electrical codes for wiring and grounding requirements.
6. Grip black supply wire firmly and push into connector port marked with black circle (opposite black ballast wire).
7. Grip white supply wire firmly and push into the remaining port.
8. Use only conductor per port and assure that no copper is exposed on any of the wires inserted.
9. Replace reflector & lens.
10. Turn on electrical supply at the breaker.

**NOTE:** Open ended portion of fixture must have listed, liquid tight strain relief bushing, suitable for cord type employed. Rated min. 90°C

**LED NOTE:** Optional 0-10 V Dimming. Dimming provided through grey & purple wires. Refer to control manufacturer for wiring instructions.

Installation Questions  
Call LSI Field Service Dept.  
800-436-7800 Fax 877-861-1368